

TM

SERIES

MONOSTABLE TIMER RELAY
MULTISCALE 4 CONTACTS

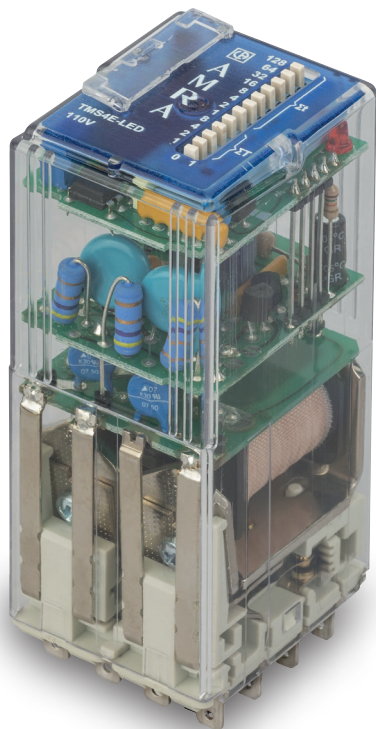

EAC

APPLICATIONS



OVERVIEW

- Time delay relay, pick-up, drop-out
- Double configuration: 4 timed contacts or 2 timed + 2 instantaneous
- Time range from 0.1s to 9 hours
- Great **accuracy over the entire range**
- High **EMC immunity**
- Solid and rugged construction for heavy and **intensive duties**
- Self-cleaning contacts
- Magnetic **arc blow-out** on all models.
- Excellent **shock and vibration resistance**
- Wide range of sockets
- Positive **mechanical keying** for relay and socket

DESCRIPTION

The TM series is a range of relays with electronic time delay on pick-up or drop-out.

It is **built on the BIPOK electromechanical base** on which is added a specific digital electronic circuit designed with few components carefully chosen among the best professional products.

With the same relay it is possible to manage a time from 0.1 second to over 9 hours, with the greatest accuracy over the entire range. This is thanks to the fact that the relay has **16 intermediate scales**, selectable by the user.

The switching time is adjustable through the dipswitches located on the front of the relay. The 4-bit dipswitch serves for selecting the most suitable intermediate scale, while the 8-bit dipswitch is used for a **precision selection of the switching time**.

On request, the models are **available with fixed switching time to avoid modifications** to the time setting.

The electronic circuit is immune to high electromagnetic interference, typical of high voltage electricity stations.

The **design and construction procedures can ensure a wide electrical life and high reliability** level also in harsh operating environments or with strong temperature fluctuations.

Excellent electrical and mechanical performance levels allow the product to be **used in the most demanding sectors** such as control and signalling functions in power plants, electrical stations, rolling stock or in industries with continuous production processes.

A specific treatment (P5GEO or P6GEO) combine the coil tropicalization with gold-plated contacts allowing the use of these relays in geothermal power plants.

STANDARD COMPLIANCE

EN 61810-1	EN 60077
EN 61810-2	EN 50155
EN 61810-7	EN 60695-2-10
EN 61373	EN 61000
EN 45545-2	EN 60529
ASTM E162, E662	



MODELS	FUNCTION		NOMINAL CURRENT		NUMBER OF CONTACTS		ROLLING STOCK APPLICATION
	Pick-up	Drop-out	5A	10A	Time-delayed	Instantaneous	
TM2E	•		•		2	2	•
TM4E	•		•		4	-	•
TMS2E	•			•	2	2	•
TMS4E	•			•	4	-	•
TM2R		•	•		2	2	•
TM4R		•	•		4	-	•
TMS2R		•		•	2	2	•
TMS4R		•		•	4	-	•



FOR PRODUCT CODE CONFIGURATION, SEE THE "ORDERING SCHEME" TABLE



COIL DATA	
Nominal voltages Un ⁽¹⁾	DC: 12-24-36-48-72-96-110-125-132-144-220 AC: 12-24-48-110-127-220-230
Max. consumption at Un	4W / 5 VA
Operating range ⁽¹⁾	80...115% Un
Rolling stock version ⁽²⁾⁽³⁾	DC: 70...125% Un
Type of duty	Continuous
Drop-out voltage ⁽⁴⁾	DC: > 5% Un AC: > 15% Un

(1) Other values on request.

(2) See "Ordering scheme" table for order code.

(3) For operating ranges different to that specified by EN60077, refer to table "Rolling stock versions - Special Ranges".

(4) Limit value for supply voltage, expressed as % of the nominal value, beneath which the relay is certainly de-energized.



CONTACT DATA	TM2E - TM2R	TM4E - TM4R	TMS2E - TMS2R	TMS4E - TMS4R
Number and type	2 + 2 instantaneous SPDT, form C	4 SPDT, form C	2 + 2 instantaneous SPDT, form C	4 SPDT, form C
Current Nominal ⁽¹⁾	5 A		10 A	
Maximum peak (1 min) ⁽²⁾	10 A		20 A	
Maximum pulse (10 ms) ⁽²⁾	100 A		150 A	
Example of electrical life expectancy ⁽³⁾	0.2 A – 110 Vdc – L/R = 40 ms : 10 ⁵ operations 1,800 operations/h		0.5 A – 110 Vdc – L/R = 40 ms : 10 ⁵ operations 1 A – 110 Vdc – L/R = 0 ms : 10 ⁵ operations	
Minimum load ⁽⁴⁾	Standard contacts	500 mW (20V, 20 mA)		
	Gold-plated contact P4GEO ⁽⁵⁾	100 mW (10V, 5 mA)		
	Gold-plated contact P8 ⁽⁵⁾	50 mW (5V, 5 mA)		
Maximum breaking voltage		250 Vdc / 350 Vac		
Contact material	AgCu		Ag / AgCu	
Operating time at Un (ms) ⁽⁶⁾⁽⁷⁾		DC ⁽⁸⁾ – AC		
Pick-up (NO contact closing)		≤ 20 - ≤ 20		
Drop-out (NC contact closing)		≤ 15 - ≤ 20		

(1) On all contacts simultaneously, reduction of 30%.

(2) The max. peak and pulse currents are those currents that can be handled, for a specified time, by the contact. They do not refer to steady or interrupted currents.

(3) For other values, see electrical life expectancy curves.

(4) Values referred to a new product, measured in laboratory. The ability to maintain this performance over the time depends on the environmental conditions and the contact' frequency use. The use of gold plated contacts is recommended in the case of very low loads.

(5) Specifications of contacts on new relay

a. Plating material: **P4 GEO**: gold-nickel alloy (>6μ) **P8**: gold-cobalt alloy (>5μ), knurled contact

b. When the gold-plated contact is subject to heavy loads, it will be degraded on the surface. In such case, the characteristics of the standard contact should be taken into consideration. This does not impair relay operation.

(6) Times for the instantaneous component of the relay.

(7) Unless specified otherwise, the operating time signifies until stabilization of the contact (including bounces). It should be added to the preset delay time.

(8) Addition of a flyback diode connected in parallel with the coil (DC version only) causes an increase in operating time when the relay drops out.

INSULATION



Insulation resistance (at 500Vdc)		
between electrically independent circuits and between these circuits and ground		> 1,000 MΩ
between open contact parts		> 1,000 MΩ
Withstand voltage at industrial frequency		
between electrically independent circuits and between these circuits and ground		2 kV (1 min) - 2.2 kV (1 s)
between open contact parts		1 kV (1 min) - 1.1 kV (1 s)
between adjacent contacts		2.5 kV (1 min) - 3 kV (1 s)
Withstand voltage at industrial frequency (1.2/50μs – 0.5J)		
between electrically independent circuits and between these circuits and ground		5 kV
between open contact parts		3 kV

MECHANICAL SPECIFICATIONS



	Mechanical life	DC: 20 x 10 ⁶ AC: 10 x 10 ⁶ operations
Maximum switching rate	Mechanical life expectancy	3,600 operations / hour
	Degree of protection (with relay mounted)	IP40
	Dimensions (mm) ⁽¹⁾	40 x 50 x 97
	Weight (g)	~ 220

1. Output terminals excluded.

ENVIRONMENTAL SPECIFICATIONS



Operating temperature	Standard	-25° to +55°C
	Version for railway, rolling stock	-25° to +70°C
Storage and shipping temperature		-40° to +85°C
Relative humidity		Standard: 75% RH Tropicalized: 95% RH
Resistance to vibrations		5g - 10 to 55 Hz - 1 min
Resistance to shock		20g – 11 ms
Fire behaviour		V0

STANDARDS AND REFERENCE VALUES



EN 61810-1, EN 61810-2, EN 61810-7	Electromechanical elementary relays
EN 61812-1	Timer relays
EN 60695-2-10	Fire behaviour
EN 61000	Electromagnetic compatibility
EN 60529	Degree of protection provided by enclosures

Unless otherwise specified, the products are designed and manufactured according to the requirements of the above-mentioned European and International standards.

In accordance with EN 61810-1, all items of technical data are referred to ambient temperature 23 °C, atmospheric pressure 96kPa and 50% humidity.

Tolerance for coil resistance, nominal electrical input and nominal power is ±7%.

RAILWAYS, ROLLING STOCK - STANDARDS



EN 60077	Electric equipment for rolling stock. General service conditions and general rules
EN 50155	Electronic equipment used on rolling stock
EN 61373	Rolling stock equipment. Shock and vibration tests, Cat 1 Class B
EN 45545-2	Fire behavior, Cat E10, Requirement R26, V0
ASTM E162, E662	Fire behaviour
CU TR 001/2011	Safety of railway rolling stock - EAC certification

RAILWAYS, ROLLING STOCK – SPECIAL OPERATING RANGES ⁽¹⁾



Nominal voltage	Minimum pick-up voltage	Maximum operating voltage	Order symbol ⁽¹⁾
24 Vdc	18	33	Z01
24 Vdc	16	32	Z02
24 Vdc	16.8	32	Z03
72 Vdc	55	104	Z01
110 Vdc	77	144	Z01

(1) To request the special range, indicate the "Z0x" symbol in the "Keying position" field in the "Ordering scheme" table.

The special range may be subject to operating specifications different from standard specifications. Please contact us for further information.



CONFIGURATIONS - OPTIONS

P2	Tropicalization of the coil with epoxy resin for use with 95% RH (@ T 50 °C). This treatment also protects the coil against corrosion which could occur by combination of the humidity with certain chemical agents, such as those found in acid atmospheres (typical of geothermal power stations) or saline atmospheres
P4GEO	Gold plating of contacts with gold-nickel alloy, thickness $\geq 6\mu$. This treatment ensures long-term capacity of the contact to conduct lower currents in harsh ambient conditions such as acid atmospheres (typical of geothermal power stations) or saline atmospheres
P5GEO	P4GEO gold-plating of contacts + P2 coil tropicalization
P6GEO	P4GEO type gold-plating, but applied to contacts, contact terminal and output terminals + P2 coil tropicalization
P7	AgCdO (silver cadmium oxide) contacts.
P8	Gold plating of contacts with gold-cobalt alloy, thickness $\geq 5\mu$, knurled fixed contact. This finish allows further improvement of the gold-plated contact performance compared to the treatment P4GEO.
LED	LED indicator showing presence of power supply, wired in parallel with the coil.
FLYBACK DIODE	Polarized component connected in parallel with the coil (type 1N4007 or BYW56 for rolling stock version) designed to suppress overvoltages generated by the coil when de-energized.
TRANSIL	Non-polarized component connected in parallel with the coil. Behaviour is similar to that of a varistor, with faster operating times.
LOW TEMPERATURE	Minimum operating temperature -50°C , only for rolling stock version (option "L").



ORDERING SCHEME

PRODUCT CODE	APPLICATION ⁽¹⁾	CONFIGURATION A	CONFIGURATION B	TYPE OF POWER SUPPLY	NOMINAL VOLTAGE (V) ⁽²⁾	KEYING POSITION ⁽³⁾ / OPTION
TM2E TM4E TMS2E TMS4E TM2R TM4R TMS2R TMS4R	E: Energy F: Railway Fixed Equipment R: Railway Rolling Stock	1: Standard 2: Diode // 3: Varistor 4: Led 5: Diode // + Led 6: Varistor + Led 7: Transil 8: Transil + Led	0: Standard 2: P2 4: P4 GEO 5: P5 GEO 6: P6 GEO 7: P7 8: P8	C: Vdc A: Vac 50 Hz H: Vac 60 Hz	012 - 024 - 036 048 - 072 - 096 100 - 110 - 125 127 - 132 - 144 220 - 230	XXX L: low temperature

Example	TMS2R	E	4	2	A	230	
	TMS2RE42-A230 - TMS2R relay, ENERGY series, nominal voltage 230 Vac, provided with LED, with P2 finish (tropicalized coil)						
	TM4R	R	1	8	C	024	L
	TM4RR18-C024 - TM4R relay, ROLLING STOCK series, nominal voltage 24 Vdc, with P8 finish (gold-plated contacts) and option "L" (low temp.)						

(1) **ENERGY:** all applications except for railway.

RAILWAYS, FIXED EQUIPMENT: application on fixed power systems and electrical railway traction.
Construction according to RFI (FS Group) specification no. RFI DPRIM STF IFS TE 143 A, if applicable.
For list of RFI compliant and type-approved products, consult dedicated catalogue "RAILWAY SERIES – RFI APPROVED".

RAILWAYS, ROLLING STOCK: Application on board rolling stock (rail-tram-trolley vehicles). Electrical specifications according to EN60077.
Also available is the **STATIONS** series, with ENEL approved material meeting LV15/LV16 specifications.
For list of ENEL compliant and type-approved products, consult dedicated catalogue "STATIONS SERIES – LV15-LV16-LV20".

(2) Other values on request.

(3) Optional value. The positive mechanical keying is applied according to the manufacturer's model.

(4) For the standard version with 4 contacts, the field must be left empty.

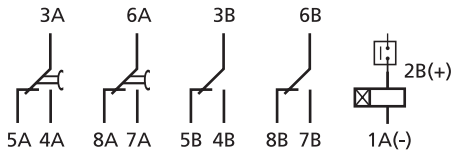

TM2E - TMS2E

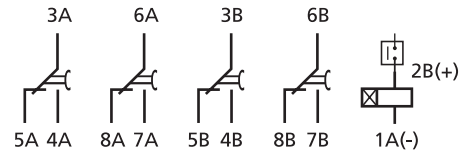

TM4E - TMS4E

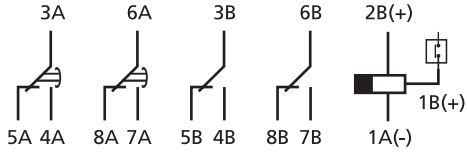

TM2R - TMS2R

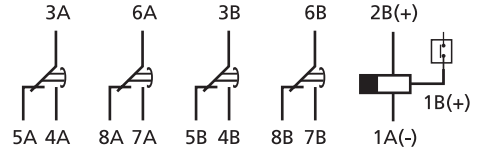

TM4R - TMS4R

Relays with time delay on drop-out require an auxiliary power supply to ensure correct timing (terminal 2B)

FUNCTIONAL DIAGRAM

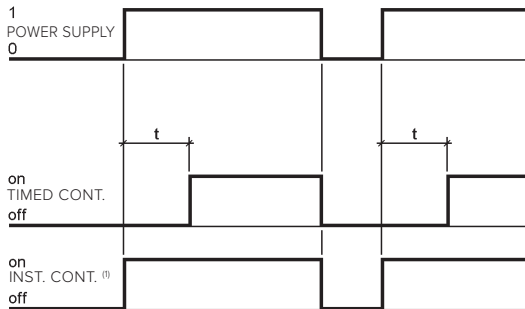

Time-delay on pick-up (version 2E, 4E)

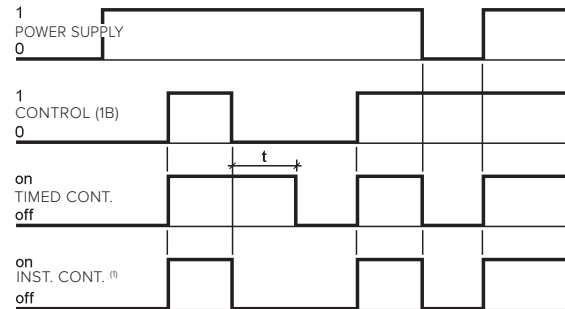

Time-delay on drop-out (version 2R, 4R)

⁽¹⁾ Instantaneous contacts are present only on versions "2E" and "2R"

TIME DELAY – SWITCHING TIME SETTING

Time setting	By means of DIP switches
Time setting range	100ms...32,768 s
Intermediate scale	16, from 1 second to 32,768 seconds
Resolution of switching time setting	1/256 of the selected scale
Accuracy, time-delay ⁽¹⁾	± 1% of the switching time ± 0.5% of the scale
Accuracy, repeatability	DC: ± 0.5% AC: ± 0.5% + 20 ms
Reset	< 100ms in time-delay phase < 400ms
Insensitivity to voltage drops	< 100 ms

(1) Additional error for drop-out versions: 100 ms

The switching time is adjustable via the dipswitches (4- and 8-bit respectively) located on the front of the relay, through which it is possible to obtain time delays from 100 ms to 32,768 seconds (about 9 hours).

To adjust the switching time, the first step is to adjust the intermediate scale T(s), by selecting one of the 16 available scales using the 4-bit dipswitch. The values available are given in table 1.

The value of the T(s) scale should be the next highest numerically than the value of the required switching time.

E.g. Switching time: 3,600 seconds → intermediate scale to set: 4096 seconds

The T(s) scale is set by identifying the switches that add up to the ΣT value indicated in table 1, and positioning them at "1".

Next, proceed to set the switching time by means of the 8-bit dipswitch.

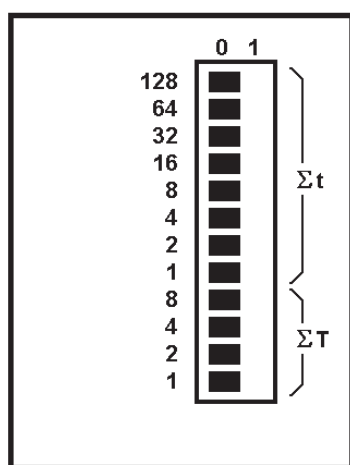

Σt
Switching time
dipswitches
(8bit)

ΣT
Intermediate scale
dipswitches
(4 bit)

T(s)	ΣT	Switch reference			
		8	4	2	1
1	0	0	0	0	0
2	1	0	0	0	1
4	2	0	0	1	0
8	3	0	0	1	1
16	4	0	1	0	0
32	5	0	1	0	1
64	6	0	1	1	0
128	7	0	1	1	1
256	8	1	0	0	0
512	9	1	0	0	1
1024	10	1	0	1	0
2048	11	1	0	1	1
4096	12	1	1	0	0
8192	13	1	1	0	1
16384	14	1	1	1	0
32768	15	1	1	1	1

Table 1

The switching time is set by identifying the 16-bit dipswitches that add up to the Σt value, as calculated below, and positioning them at "1":

$$\Sigma t = \frac{t \times 256}{T} \text{ where } t(s) : \text{required switching time} \quad T(s) : \text{full scale time set previously}$$

Example: Relay with time delay 22sec. and full scale time 32sec.

For the full scale time of 32 s, select value 5 in the ΣT column (see table), then identify the switches corresponding to 4 and 1 (4+1=5) and position them at "1". For the delay time of 22 s, set an Σt value of 176 (i.e. 22x256/32), then identify the switches corresponding to 128, 32 and 16 (128+32+16=176) and position them at "1".

DIMENSIONS

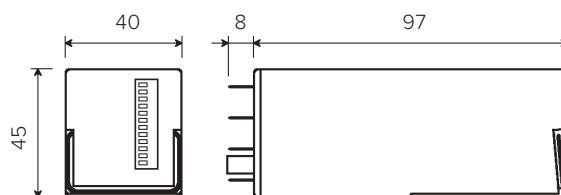

SOCKETS

Number of terminals	16
For wall or rail mounting	
Spring clamp, wall or DIN H35 rail mounting	PAIR160
Screw, wall or DIN H35 rail mounting	48BIP20-I DIN
Screw, wall mounting	48BL
For flush mounting	
Spring clamp	PRIR160
Double faston (4.8 x 0.8 mm)	ADF2
Screw	43IL
For mounting on PCB	
	65

For more details, see specifications of mounting accessories.

RETAINING CLIPS – CORRESPONDENCE WITH SOCKETS

Number of clips per relay	1, 2 for use on rolling stock
SOCKET MODEL	CLIP MODEL
For wall or rail mounting	
PAIR160, PRIR160, 48BIP20-I DIN, 48BL	RT48
For flush mounting	
ADF2	RT48
43IL ⁽¹⁾	RT43
For mounting on PCB	
65	RT43

(1) Insert the clip before fastening the socket on the panel.

ELECTRICAL LIFE EXPECTANCY ⁽¹⁾

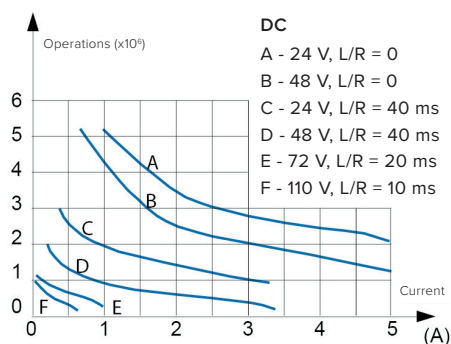

Some examples of electrical life expectancy

48Vdc - 5 A - L/R 10 ms : 5×10^5 operations
 80Vdc - 5 A - Resistive : 5×10^5 operations
 110Vdc - 0.5 A - L/R = 10 ms : 5×10^5 operations

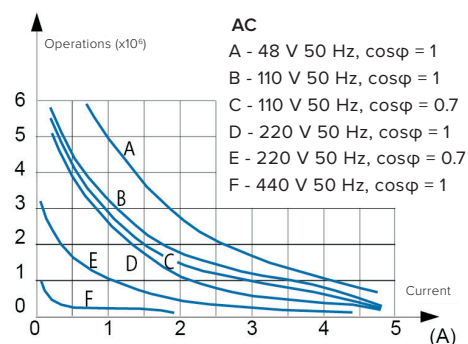

220Vdc - 0.2 A - L/R = 10 ms : 10^5 operations
 110Vac - 5 A - $\cos\phi = 0.7$: 5×10^5 operations
 220Vac - 3 A - $\cos\phi = 0.7$: 5×10^5 operations
 440Vac - 0.2 A - Resistive : 5×10^5 operations

(1) Switching frequency 1,200 operations/hour, cycle 50%.



Installation

Before installing the relay on a wired socket, disconnect the power supply.

The preferential mounting position is on the wall, with the relay positioned horizontally in the "reading orienting" of marking so that the label is readable in the correct sense.

Spacing: the distance between adjacent relays depends on use' conditions.

If a relay is used in the "less favorable" conditions that occur with "simultaneously":

- Power supply: the maximum allowed, permanently
- Ambient temperature: the maximum allowed, permanently
- Current on the contacts: the maximum allowed, permanently
- Number of contacts used: 100%

it is strongly recommended to space relay at least 5 mm horizontally and 20 mm vertically, to allow for proper upward heat' dissipation and increase the longevity of the component.

Actually, relays could be used in less severe conditions. In this case, the distance between adjacent relays can be reduced or abolished. A correct interpretation of the use' conditions allows the optimization of the available spaces. Contact AMRA for more information.

To increase relay' longevity, we recommend mounting relays intended for "continuous use" (permanent power supply), alternating them with relays intended for less frequent use.

For a safe use, the retaining clip is recommended.

For use on rolling stock, relays have been tested to EN 61373 standard equipped with retaining clip(s).

Operation

Before use: if relay is not used, for example after long storage periods, contact resistance may increase due to a natural and slight oxidation or polluting deposits.

In order to restore the optimal conductivity and for standard contacts (NOT gold plated) it is recommended to switch several time a load of at least 110Vdc - 100mA or 24Vdc - 500mA. The contacts will be "cleaned" thanks to the electric arc generated during the current interruption and the mechanical self-cleaning action.

The common contact rubs against the fixed poles (NO and NC contacts) both when opening and when closing, which ensures a self-cleaning action.

An increase in contacts' resistance, in most cases, does not represent a problem. Many factors contribute to the correct use of contact and consequently to the relay' long-term reliability:

- **Load:** the current switching generates an electric arc with cleaning effects. For proper electrical cleaning and performance keeping we recommend:
 - o Standard contacts: Minimum current = 20mA
 - o Gold plated contacts: Minimum current = 10mA
- **Operating frequency:** relays are components that can operate with a wide range of switching frequency. High frequency operation also allows a continuous cleaning effect by "sliding" (mechanical cleaning). In case of low frequency operation (for example few time a day), we advise:
 - o Use of contact with currents twice compared to those indicated.
 - o For currents lower than 10mA, use gold plated contacts and connect 2 contacts in parallel, in order to reduce the equivalent contact resistance
- **Pollution:** the presence of pollution can cause impurities on contact surface. Electric charges attract organic molecules and impurities that are deposited on the contact surface. Electrical and mechanical cleaning, respectively, burn and remove such impurities. In pollution presence, the minimum recommended currents must be respected. In extreme cases, provide double the cleaning current.

Condensation is possible inside the relay when energized and the outside ambient temperature is cold; this is quite normal and does not affect the operation of the relay. Plastic materials of relay do not possess hygroscopic properties.

Maintenance

No maintenance is required.

In case of normal relay wear (reaching the end of electrical or mechanical life), the relay cannot be restored and must be replaced.

To check the component, relay removal must be carried out with slight lateral movements. An “up and down” movement can cause terminals damage.

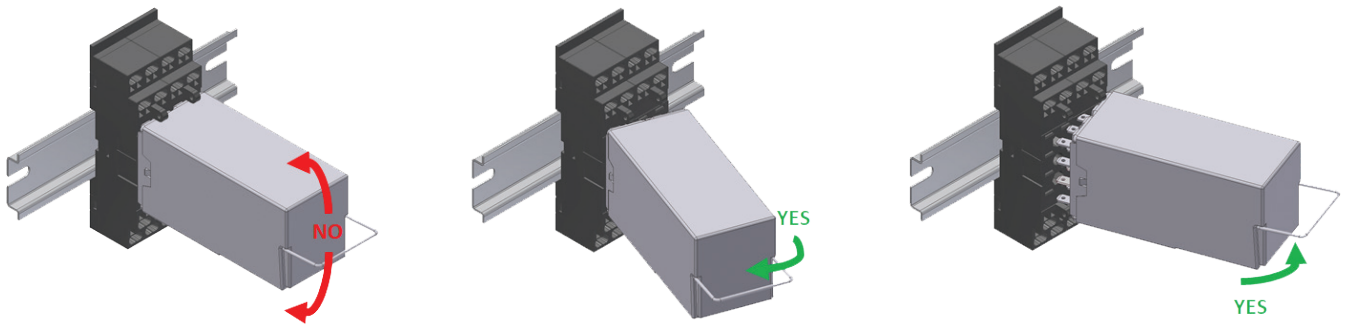

Often the malfunctions are caused by power supply with inverted polarity, by external events or by use with loads exceeding the contact performance.

In case of suspected malfunction, energize relay and observe if mechanical operation of contacts / relay mechanism is performed. Pay attention to the power supply polarity, if relay is equipped with polarized components (example: diode, led).

- In case of expected operation, clean the contacts (see paragraph "OPERATION") and check if the circuit load ranges within the contact performance. If necessary, replace with relays with gold contacts. Note: the electrical continuity of contacts must be checked with adequate current.
- If it does not work, we recommend to use a relay of the same model and configuration.

If an investigation by AMRA is required, pull-out the relay from the socket, don't remove the cap, avoid any other manipulation and contact us. You will be asked for the following data: environmental conditions, power supply, switching frequency, contact load, number of operations performed.

The fault can be described through the “TECHNICAL SUPPORT” section of the website www.amra-chauvin-arnoux.it.

In any case, the relay cannot be repaired by the user.

Storage

Storage conditions must guarantee the environmental conditions (temperature, humidity and pollution) required for the product conservation, in order to avoid deterioration.

The product must be stored in an environment sheltered from atmospheric agents and not polluted, with an ambient temperature between -40 and +85°C with max 75% RH. Humidity can reach peaks of 95%. In any case, there must be no condensation. Before use, please read carefully “OPERATION” section.